



*heating and plumbing products
that won't cost the **earth***

Solarlogic Maxi pump station

July 2010



Solarlogic Maxi pump station

Solarlogic Maxi has been designed for the integral mounting of the Intaeco Solarlogic controller.

It also provides larger internal dimensions for a future changeover to high energy efficient pumps, both 130mm and 180mm.

From 1st January 2013, the EUP (energy using products initiative), an energy efficiency index will be applied to pumps of 0.27 (calculation rating) and below. These pumps will require a larger internal dimension allowance within the insulation jacket

Solarlogic Maxi pump group for the circulation of glycol mix fluids through solar thermal heating applications provide:

- filling and flushing connection points,
- fluid flow regulation
- system temperature and pressure readings,
- check valve for anti-gravitation
- safety pressure relief valve and discharge connection,
- point of connection for expansion vessel and isolation
- isolation of upper and lower system levels and pump

Models

The **Solarlogic single line pump group** is for RETURN pipe connection and pumps into the solar collector, circulating by provision of the installer of a flow line to the hot water storage cylinder heat exchanger and back to the pump.

Connections are for 22mm copper (compression).

The **Solarlogic twin line pump group** is for RETURN and FLOW pipe connections into the solar collector and flow back to the pump group, through the isolation valve and through the air separator. Flow into and through the hot water storage heat exchanger and return to the pump.

Connections are for 22mm copper (compression).

Or

$\frac{3}{4}$ " male threads with made for purpose flat face on the upper or solar panel side of the group, intended for connection to Intaeco annular type pipe size DN16.

Or

a mix of both. 22mm on the lower pump station connections, for "hard" piping to the storage cylinder with 22mm copper and $\frac{3}{4}$ " male upper connections for connecting onto DN16 stainless steel flexible pipes.

The plastic cover conceals a storage compartment for the installer documents or service history.

The Solarlogic controller can be mounted directly into the housing.



Solarlogic maxi twin line pump station (controller not fitted)



Solarlogic maxi twin line pump station (cover removed)

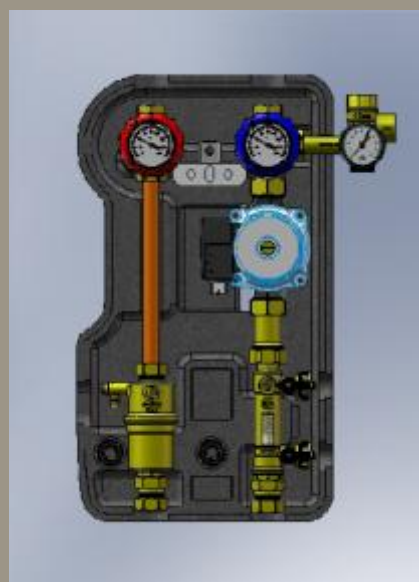

Solarlogic Maxi pump station

Main components

Flowmeter, flow rate regulation and graduated scale regulation gauge.

2-12 litre/min isolation valves for filling/flushing of the unit. Connections $\frac{3}{4}$ "M with safety chain and tap.

Circulator - WILO solar STAR ST15-6ECO, connections 1"BSP - 130mm class. TF110, VDE, CE.

Return side isolation valve DN20, with integrated bracket. Connection $\frac{3}{4}$ "M always open on one side. Check valve activation. Closure at 90° and opening at 45°. Integrated high temperature check valve.

Check valve opening 2kPa (200mm c.a.)

Safety group with 6 bar safety valve certified TUV according to SV100 7.7 - directive 97/23/CE. Vertical threaded connection to expansion tank $\frac{3}{4}$ "M BSP with flat gasket connection.

Pressure gauge 0-10 bar

Thermometer on return side, colour blue, range 0-160°C.

Thermometer on flow side, colour red range 0-160°C.

Airstop deaerator on the flow side. Traps air automatically, manual vent.

Steel wall fixing bracket, front end retainer & safety screw

Hose end connections, filling/flushing device. $\frac{3}{4}$ " hose union.

Insulation jacket black ppe, density 40kg/m³, plain

Technical data

Fluid	water to glycol ratio max 50%
Safety valve	6 bar
Pressure gauge	0-10 bar
Thermometer gauge	0-160°C
Min. pressure to open check valve	2kPa (200mm c.a.)
Electric supply	230-240v 50 Hz
Max run temperature	130°C
Max. peak temperature	150°C



Thermometers



Air deaerator

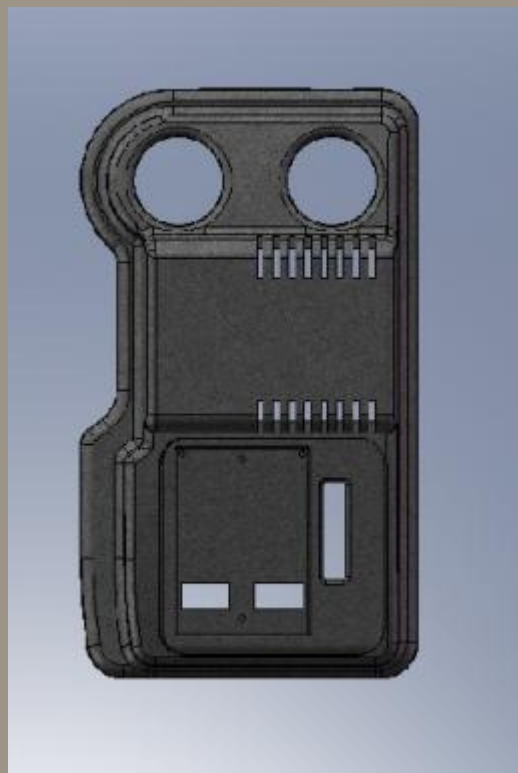

pump station cover

Solarlogic Maxi pump station

Components Pump - Wilo ST15.6 ECO

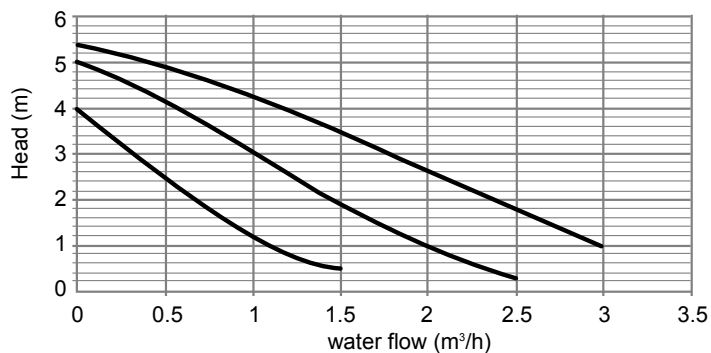

Components Pump - Wilo ST15.8 ECO

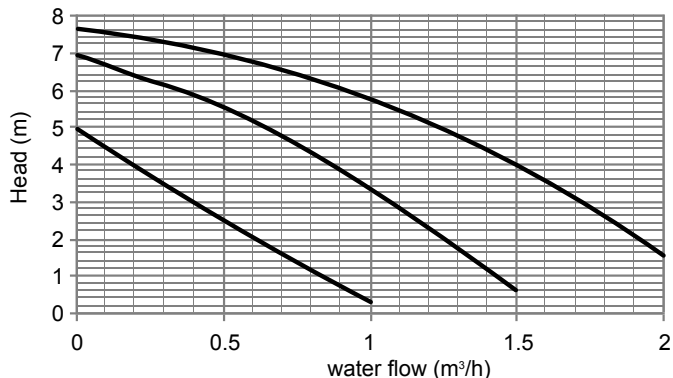

The solar circulating pump data

Tolerances according to EN 1151-1:2006

Product	Speed	P1 (500l/h) W	I (500l/h) A	Capacitor μ F/VDB
ST../6 ECO	max	49	0.22	2/400
	med	43	0.19	
	min	36	0.16	

Product	Speed	P1 (500l/h) W	I (500l/h) A	Capacitor μ F/VDB
ST15/8 ECO	max	86	0.37	3/400
	med	53	0.26	
	min	47	0.21	

Assembly

The Solarlogic controller mounts directly on to its purpose made housing.

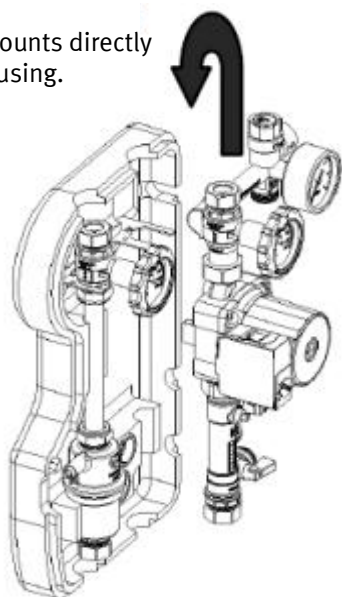

The WILO solar circulating pump has a molex plug in connection. Lead and plug are provided.

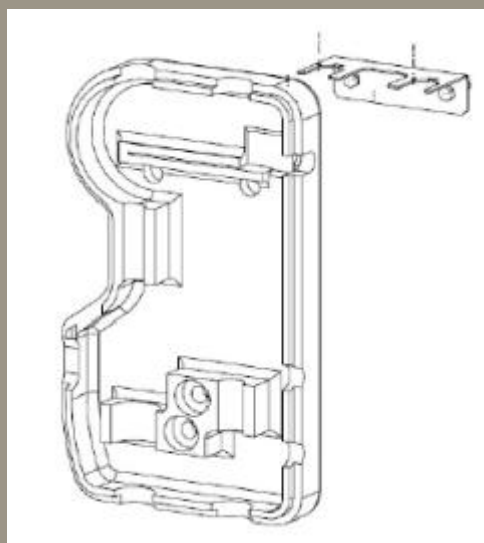

Intaeco Limited
Airfield Industrial Estate, Hixon, Stafford ST18 0PF

t: 0870 220 9666 f: 01889 272181
e: sales@intaeco.co.uk w: www.intaeco.co.uk

