

# Intasol Control System

## Installation Guide



## Introduction

The Intaeco Intasol manifold allows unvented hot water, heated by solar thermal panels to be used safely with a combination boiler. The Intasol system automatically controls and optimises the thermal energy contained in a solar water storage system at a controlled optimum temperature.

The Intaeco Intasol system comes complete with an anti-scald TMV2 thermostatic mixing valve, thermostatic diverting valve, thermostatic blending valve and integral non return valve.

The system ensures that users always receive hot water at the set temperature and diverts cold water at 28°C to activate the boiler if the temperature of the water coming from the solar storage cylinder falls below 55°C.

The compact design of the Intaeco Intasol manifold has all valves housed in one body and comes complete with connections suitable for copper tube.

## Technical Specification

Connections:	15mm compression for copper tube
Body material:	DZR copper alloy BS EN 12164 CW602N
Shutter:	UDEL GF-120NT
Spring:	Stainless Steel AISI 302

### Thermostatic Mixing Valve

Max. working pressure:	10 bar (static); 5 bar (dynamic)
Adjustment range:	35 to 55°C
Accuracy:	±2°C
Max. inlet temperature	100°C
Max. inlet pressure ratio (H/C or C/H)	2:1
Minimum temperature difference between the inlet hot water and the outlet mixed water to ensure anti-scald performance:	10°C
Min. flow rate for stable operation:	6 l/min

### Thermostatic Diverting Valve

Max. working pressure:	10 bar (static); 5 bar (dynamic)
Factory set:	48°C
Maximum inlet temperature:	100°C

### Thermostatic Blending Valve

Max. working pressure:	10 bar (static); 5 bar (dynamic)
Factory set:	28°C
Maximum inlet temperature:	90°C

## High Temperatures and Solar Systems

The temperature of the domestic water in solar thermal systems can reach very high temperatures over long periods.

In summer, especially if there is little water usage, the hot water can reach a temperature around 98°C before the temperature and pressure safety relief valves are actuated.

At these temperatures the hot water cannot be used directly because of the danger of scalding to the user.

Water temperatures over 50°C can cause burns very quickly, for example at 55°C partial burns occur in about 30 seconds and at 60°C they can occur in about 5 seconds.

The Intasol incorporates a TMV2 thermostatic mixing valve which blends the hot and cold water to deliver blended water at a safe temperature.

**Features**

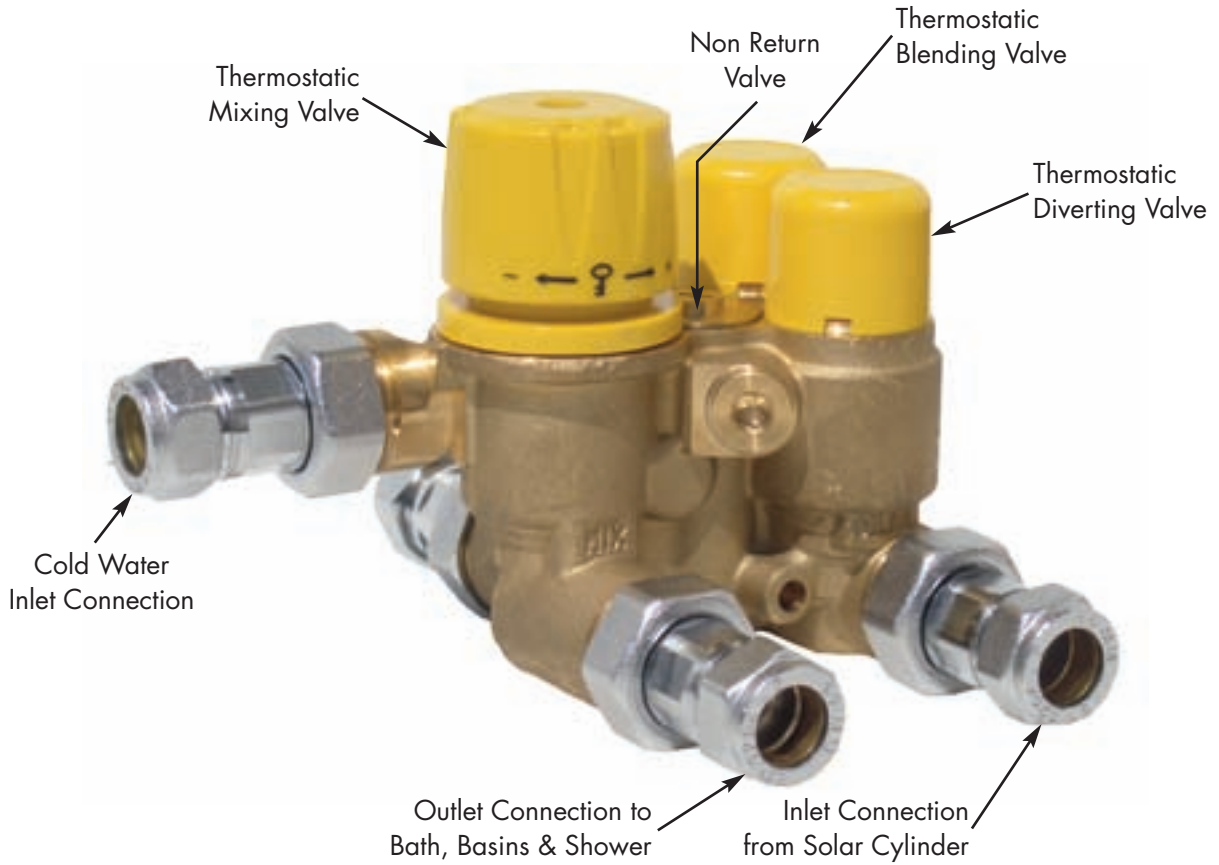

**Reverse View**

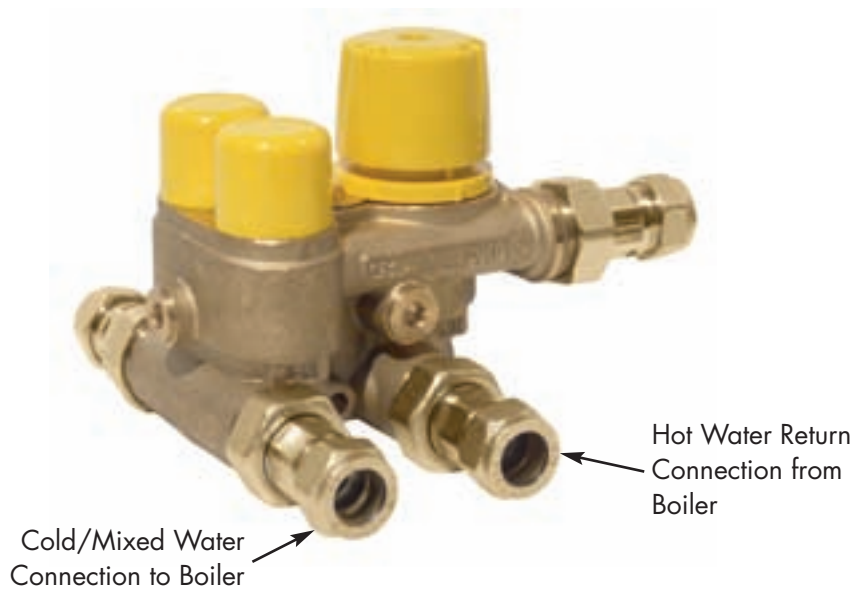

## Dimensions

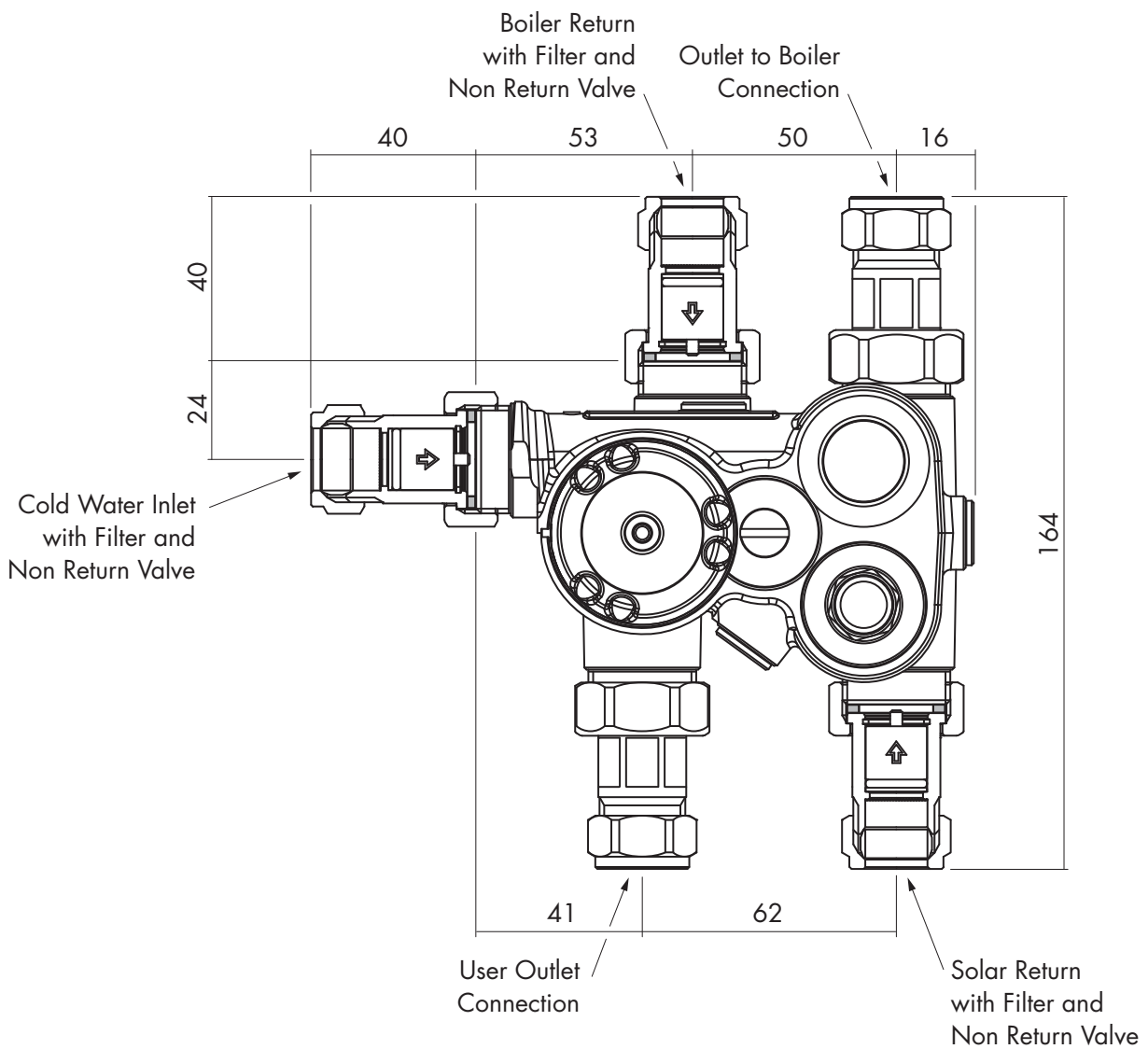
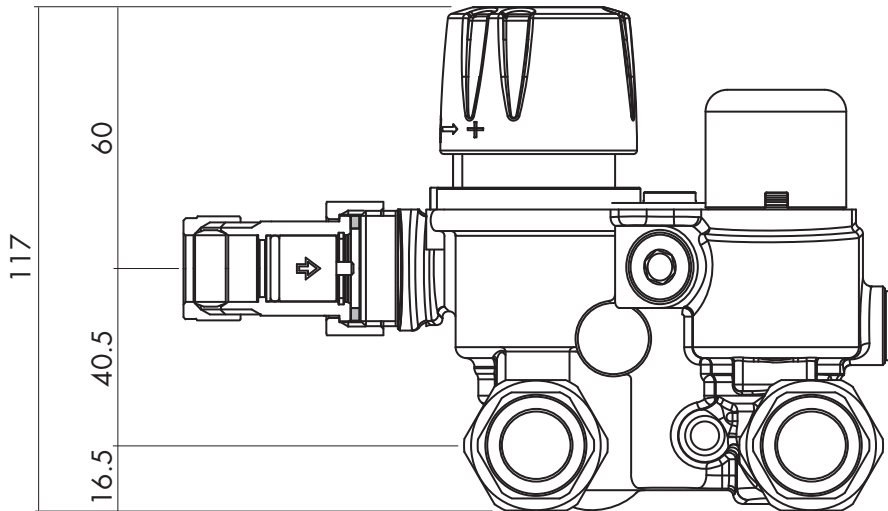

## Schematic Diagrams

### Sunny Weather

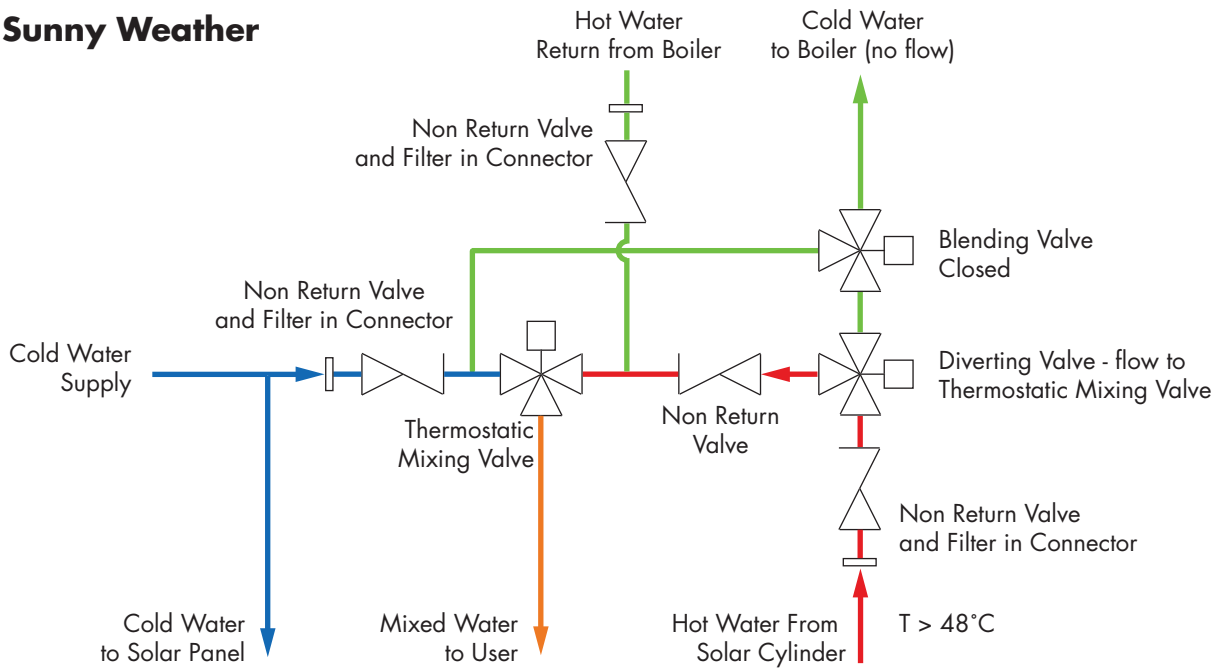

### Rainy Weather

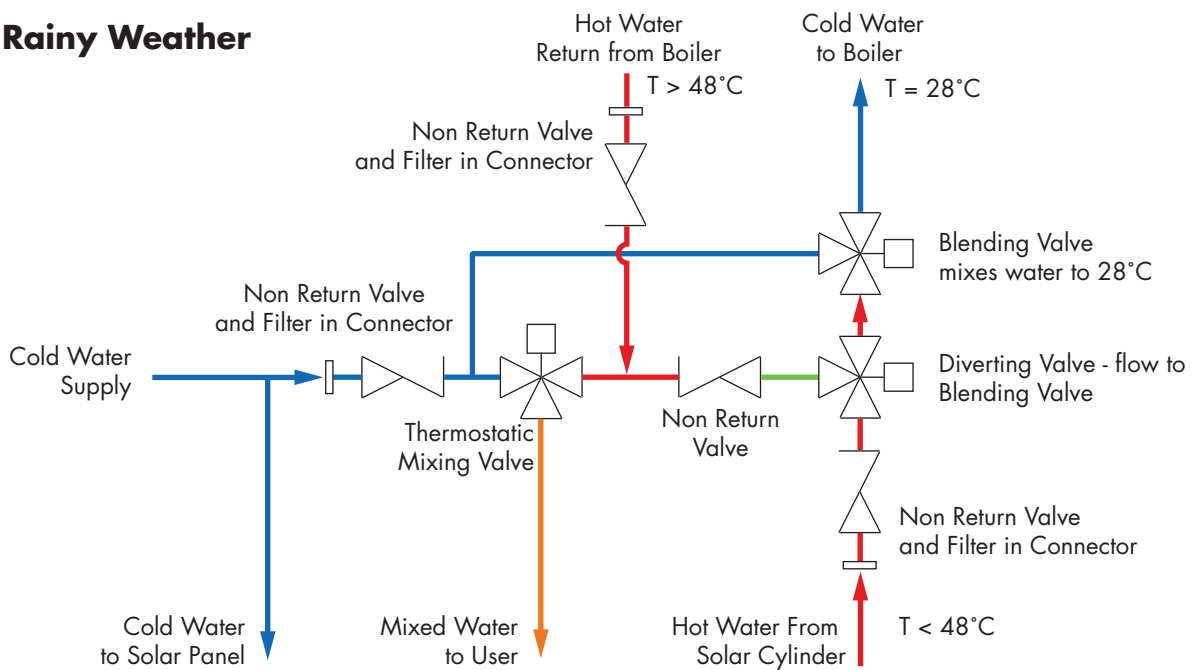

Inactive

Hot Water

Cold Water

Blended Water

## Typical Circuit

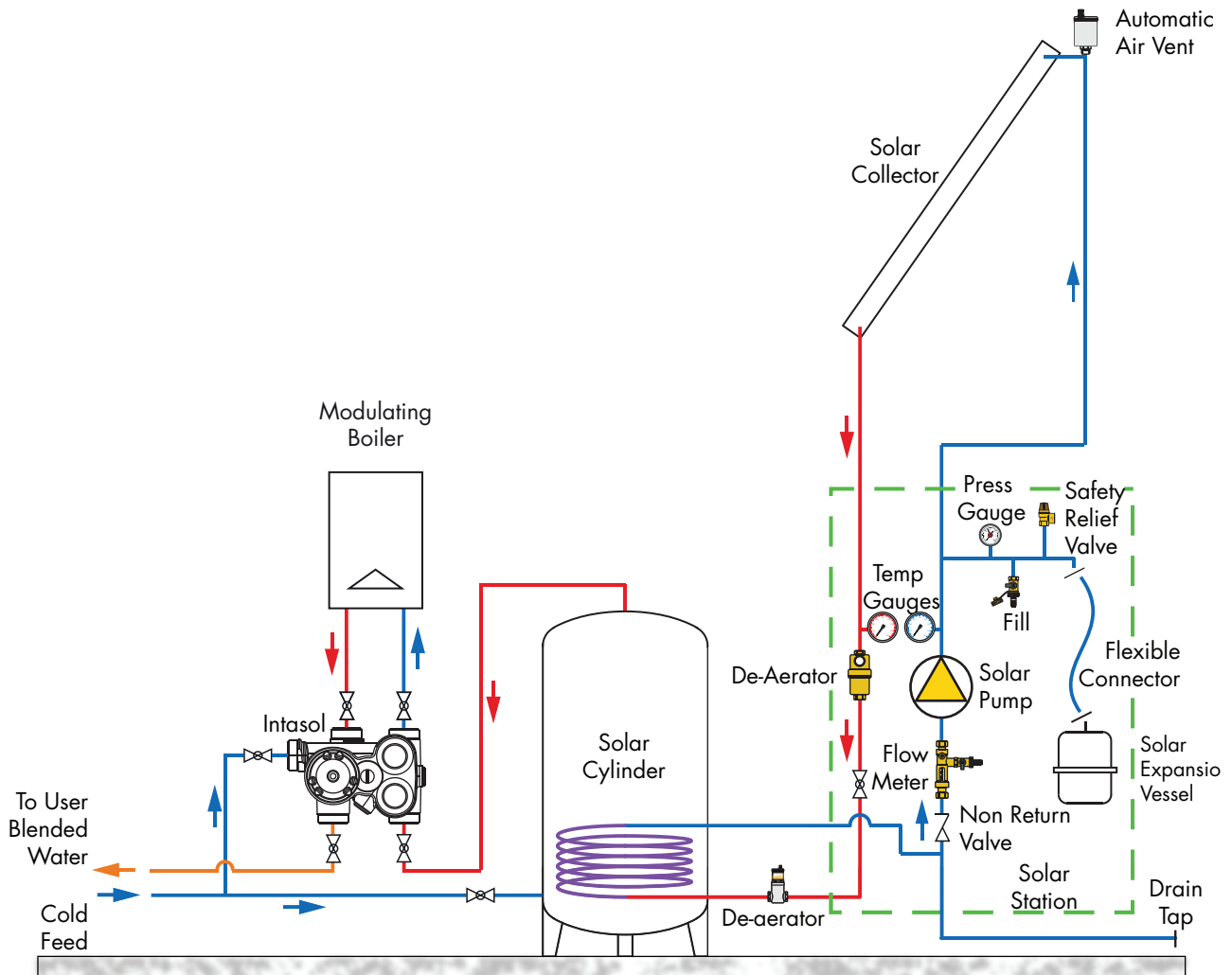

## Installation

**IMPORTANT** - The following instructions must be read prior to the installation of any Intaeco Intasol manifold. The installer should also be aware of its responsibility and duty of care to ensure that all aspects of the installation comply with current regulations and legislation.

The Intasol manifold should be preferably installed close to the boiler, on the outlet from the solar hot water storage, to ensure a constant temperature of mixed water is supplied to the user.

The Intasol manifold must be fitted in a circuit similar to the typical one shown above.

To ensure that maintenance, commissioning and testing can be undertaken easily the Intasol manifold **MUST** be installed in an accessible position

Given the flow characteristics of the integral thermostatic mixing valve, the Intasol can be used for a single outlet, eg. washbasin, shower, or for multiple outlets.

To ensure the mixed water is supplied at the set temperature, a minimum flow rate of 6 l/m is required.

The installation of thermostatic mixing valves must comply with the requirements of the Water Supply (Water Fittings) Regulations 1999.

## Installation

**Note:** The Intasol manifold is supplied with 5 compression joint to union connectors 3 of which contain a non return valve and filter these must be fitted on the cold water supply, return from the solar storage cylinder and return from the boiler connections

Use BS EN 1057 (half hard) copper tube with compression joints to BS EN 1254-2

Flushing through water systems using certain chemicals may wholly or partially remove the lubricant from the internal workings of the valves, which may adversely affect their performance. We recommend that following chemical flushing of the system, valves are checked for correct operation.

- 1 It is essential that before installing the Intasol manifold the supply conditions of the system to which the valve is intended to be fitted are checked to confirm compliance with the parameters as quoted within the Technical Specification i.e. verify supply temperatures, supply pressures, risk assessment.
- 2 Consideration must be made for the possibility of multiple / simultaneous demands being made on the supply system whilst the Intasol is in use, therefore all practical precautions must be made to ensure that the valve is not affected. Failure to make provision with pipe sizing etc. will affect the performance of the valve.
- 3 The supply system into which the Intasol manifold is to be installed must be thoroughly flushed and cleaned to remove any debris which may have accumulated during installation. Failure to remove any debris will affect the performance and the manufacturer's warranty of the product. Independent filters / check valves and isolation valves must be fitted in conjunction with the valve. In areas that are subject to aggressive water, provision must be made to treat the water supplies prior entering any Intaeco product.
- 4 The maximum flow rate of the Intasol will only be achieved when the supply conditions are achieved as quoted within the Technical Specification, with a flow condition under 1 bar differential pressure.
- 5 The Intasol manifold has been designed to ensure that the valve can be installed in any orientation and can be surface mounted or within a supply duct. It is essential that access to the manifold is not obstructed for any future maintenance that may be required to the Intasol or associated fittings.
- 6 The hot and cold water supplies must be connected to the Intasol manifold strictly in accordance with the indications on the body of the manifold.
- 7 In a situation where the water supplies are excessive, it is possible to fit a pressure reducing valve to reduce the pressure(s) to within the limits as quoted previously.
- 8 The Intasol must be fitted with a back flow prevention device, such as check valves to prevent the cross contamination of supplies. The Intasol is complete with integral check valve and strainer, on the cold water inlet, return from the solar storage cylinder and return from the boiler.
- 9 Y Pattern strainers and full-bore isolation valves must be installed in conjunction with the Intasol manifold – the Y Pattern Strainers and isolation ball valves must be fitted as close a practically possible to the manifold.
- 10 It is essential that the Intasol should not be installed in situations where there is a possibility of the valve being deprived of water or where demands for water are greater than the actual stored supplies.
- 11 To ensure that the performance levels of the Intasol are maintained (in the event of cold water failure), the temperature of the hot water supply at the point of entry to the valves must be a minimum of 10°C above the commissioned blended water discharge temperature.
- 12 The Intasol must not be subject to any extreme temperature variations either during the installation or under normal operating conditions.

## Recommended Outlet Temperatures

The Buildcert TMV scheme recommends the following set maximum mixed water outlet temperatures for use in all premises:

Application	Recommended Set Mixed Water Temp.
Wash Hand Basin	41°C
Shower	41°C
Bidet	38°C
Bath Fill	44°C

The mixed water temperatures must never exceed 46°C. The maximum mixed water temperature can be 2°C above the recommended maximum set outlet temperatures.

**NOTE:** 46°C is the maximum mixed water temperature from the bath tap. The maximum temperature takes account of the allowable temperature tolerances inherent in the thermostatic mixing valves and temperature losses in metal baths. It is not a safe bathing temperature for adults or children.

The British Burns Association recommends 37°C to 37.5°C as a comfortable bathing temperature for children. In premises covered by Care Standards Act 2000, the maximum mixed water outlet temperature is 43°C

## Method of Adjusting the Mixed Water Outlet Temperature

**IMPORTANT** - The following instructions must be read and understood prior to the adjustment of the mixed water outlet temperature and this action **MUST** only be carried out by a suitably qualified person.

- 1 Remove the cap from the valve
- 2 Remove the temperature locking ring from the spindle using a suitably sized spanner
- 3 Open the outlet to which the mixing valve is supplying and establish as stable flow and temperature
- 4 Using a calibrated thermometer place the sensing part of the thermometer probe under the flowing water
- 5 Using a suitably sized spanner turn the temperature adjustment spindle clockwise to increase the mixed water temperature or anti clockwise to reduce the mixed water temperature – at all times ensuring the probe of the thermostat is under the flowing water.
- 6 Once the desired temperature is reached – replace the temperature locking ring on the spindle and re-fit the cap to the valve.
- 7 Set the mixed water temperature to the required temperature. **The temperature at the terminal fitting must never exceed 46°C.**

## Commissioning

**IMPORTANT** - The following instructions must be read and understood prior to commissioning the Intasol manifold incorporating a thermostatic mixing valve. When measuring any mixed water outlet temperature reading, the sensing part of the thermometer probe must be fully submerged in the water. If under any circumstances there are aspects to the installation / system which do not comply with the specification laid down, the valve **MUST NOT** be put into operation until the system / installation complies with our specification. However if all these conditions are met, proceed to set the temperature as follows;

- 1 Ensure the designation of thermostatic mixing valve matches the application and that the system is thoroughly cleaned and free from any debris prior to the commissioning of the Intaeco range of thermostatic mixing valves and the supply temperatures and pressures are within the valve's operating range specified. Providing that all of these conditions are met, follow the following steps to commission this product.

## Commissioning

- 2 The commissioning of the temperatures must be carried out using a suitably calibrated thermometer – preferably a digital thermometer the sensing part which must be fully submerged in the water when testing.
- 3 Each valve must be commissioned taking into consideration any fluctuations, which may occur within the system due to simultaneous demands. It is advisable that any outlets which are connected to the same supply as the mixing valve are open during setting of the blended water temperature. During commissioning it is advisable to ensure that the water temperatures are established before any attempt to commission.
- 4 Once the supply temperatures are stable and the normal operating conditions are established, the valve can be commissioned, – the temperature setting can be adjusted by removing the cap and temperature locking ring from the valve body (see section method of adjusting mixed water temperature). The following sequence should be followed when commissioning the valve;
  - 4.1 Set the mixed water temperature to the required temperature. The temperature at the terminal fitting must never exceed 46°C.
  - 4.2 Measure and record the temperature of the hot and cold water supplies at the connection to the valve.
  - 4.3 Measure and record the temperature of the water discharging from the valve.
  - 4.4 Isolate the cold water supply to the valve and monitor the mixed water temperature.
  - 4.5 Measure and record the maximum mixed water temperature and the final temperature. The final temperature found during the test should not exceed the values quoted
  - 4.6 Record all the equipment used during the commissioning.
  - 4.7 The mixed water temperature at the terminal fitting must never exceed 2°C above set temperature.
  - 4.8 The maximum mixed water supply temperature at the terminal fitting should not exceed 46°C.
- 5 Once the desired temperature is established remove the cap and secure the temperature spindle with the locking ring and replace the cap into its original position to prevent tampering by unauthorized persons. Ensure that the application in which the valve will be used is appropriate for the approved designation.
- 6 The above information must be recorded and updated on every occasion when any work is carried out on the valve.

## In Service Testing

The thermostatic mixing valve of the Intasol should be tested against the original set temperature results once a year. It is a requirement that all TMV2 approved valves shall be verified against the original set temperature results once a year. When commissioning/testing is due the following performance checks shall be carried out. When measuring any mixed water outlet temperature reading the sensing part of the thermometer probe must be fully submerged in the water.

When testing is due the following performance checks shall be carried out;

- 1 Measure the mixed water temperature at the outlet.
- 2 Carry out the cold water supply isolation test by isolating the cold water supply to the TMV, wait for five seconds if water is still flowing check that the temperature is below 46°C.
- 3 If there is no significant change to the set outlet temperature ( $\pm 2^\circ\text{C}$  or less change from the original settings) and the fail-safe shut off is functioning, then the valve is working correctly and no further service work is required.
- 4 If there is a residual flow during the commissioning or the annual verification (cold water supply isolation test), then this is acceptable providing the temperature of the water seeping from the valve is no more than 2°C above the designated maximum mixed water outlet temperature setting of the valve. Temperature readings should be taken at the normal flow rate after allowing for the system to stabilise

## In Service Testing

- 5 If the thermostatic mixing valves of the Intasol has been adjusted or serviced it must be re-commissioned and re-tested in accordance with these instructions.

## Problem Solving

The following details are supplied for on site queries, should you require any further assistance our Technical Department can be contacted directly on 01785 218220

### 1 Hot water at the cold tap

- i. Operation of the check valve insert is hindered, confirm the valve is seated correctly.
- ii. Check Valves not fitted.
- iii. Unbalanced hot/cold supply pressure.

### 2 Fluctuating mixed water temperature

- i. Erratic supply temperatures at the inlets of the valve.
- ii. Starvation of the water supplied at the inlets of the valve.
- iii. Incorrect commissioning of the valve.

### 3 Erratic flow

- i. Insufficient water supplies.
- ii. Fluctuations in the supply pressures/temperatures.
- iii. Adverse effect created by other draw off points on the system.

### 4 No flow/reduced flow from valve

- i. In line filters are blocked.
- ii. Insufficient supply pressure.
- iii. Debris obstructing valve operation.
- iv. Valve requires servicing (Servicing kits available on request).

### 5 Valve does not fail safe when tested

- i. Installation not in accordance with our recommendations.
- ii. The minimum temperature differential not achieved.
- iii. Internal mechanism hindered by debris.

Please leave this Manual for the User



**Intaeco Ltd**  
Mustang Drive  
Stafford  
Staffordshire  
ST16 1GW

Tel: **01785 218220**  
Fax: **01785 218221**  
email: **sales@intaeco.co.uk**  
web: **www.intaeco.co.uk**