

## Solar motorized valves

### Introduction

This booklet is not a complete description of the valve nor a detailed illustration of how it functions. It contains all the user normally needs for the proper and safe use and maintenance of the valve. Select valves based on the technical and hydraulic characteristics. Valves must be installed in accordance with these instructions.

Packing and all that is contained in packaging (polystyrene, plastic bags etc) must be kept out of the reach of children because it is a potential source of harm if ingested. The product must be stored where it is protected from humidity, dust and dirt. Failure to comply with the instructions contained in this manual, negligence, poor or mistaken use of the valve will cause invalidation of guarantee coverage and eliminates all of the manufacturer's responsibilities for any damage that may be caused. The manufacturer guarantees its products for a period of 12 months from date of manufacture. This guarantee covers exclusive free repair or replacement of those parts which, after careful examination by our engineering office are held to be defective.

The guarantee excludes all responsibility for direct or indirect damages and is limited to defects in materials. It ceases to have effect whenever the parts that have been returned to us have been dismantled, tampered with or repaired outside of our factory. Goods that are returned, even if they are under guarantee must be delivered carriage paid. Damage caused by negligence, neglect, poor use or improper use of the valve is excluded from guarantee coverage. Removal of safety devices on the valve also cancels the guarantee and the responsibility of the manufacturer. Each valve carries a nameplate to permit identification. The nameplate carries:

- manufacturer's name and address
- CE brand
- series or type
- serial number (lot number) when present
- year of manufacture
- principal technical data

It is prohibited to use the valve in machines / mechanical systems before these machines / systems have been certified to comply with the directives. The valve can be returned to the manufacturer at the end of its life cycle by shipment carriage paid.

### Instructions prior to installation

The valve must be connected to systems that are compatible with its performance capabilities. Check, before connecting it to any system, that;

- plant pipelines have been flushed out to remove all residue.
- the axis of paths A and B in the valve body is at least 135mm distant from external restrictions that could make it difficult or impossible to remove the valve cover.
- the valve is not installed upside down, with the cover facing down.
- the electrical connection voltage is the same as the voltage indicated on the valve box.
- the pressure of the connection to water mains and the

pressure difference between paths A and B or AB are suitable for valve operation (see Technical Data). It's also important to note that valve surface temperatures can be quite high when it is carrying high temperature fluids. We recommend that operators or users employ protective devices (gloves etc).

### Instructions prior to start-up

Electrical safety of the valve is achieved only when the valve is correctly connected to an effective ground system made according to system safety regulations (Law dated March 5 1990 no. 46). The valve must be electrically connected to a single-phase supply grid using the three pole cable and respecting ground phases. The electrical supply is controlled by an external control device (thermostat etc). Make sure that nameplate data correspond to supply grid data. If the power supply cable is replaced it must be replaced by a standardized "HAR105 VV-F" or "HAR HT105" 3 x 0.75mm cable.

### Access to electrical components

- always isolate the electrical power supply before performing any electrical work.

- unscrew the screw that fastens the cover and remove it to access the electrical terminals.

Motor supply

(L) = brown line

(N) = Light blue neutral

(⊥) = Yellow-green ground

| Auxiliary switches             | Microswitch signal output |       |        |       |
|--------------------------------|---------------------------|-------|--------|-------|
|                                | M1                        | M1S   | M2S*   |       |
| No. of microswitches installed | 1                         | 1     | 1*     | 2*    |
| C (common)                     | black                     | black | black  | green |
| NO (normally open)             | black/(grey)              | grey  | orange | white |
| NC (normally closed)           | /                         | red   | grey   | red   |

### Manual lever

A lever is placed on the side of the cover and permits manual positioning of the shut-off in an intermediate position. This permits, in the case of a two-way valve, the valve to be kept open and, in the case of a three way valve, to keep paths A and B simultaneously open. To do this, just push it forward and lock it in the "MAN" position, locking it in the tooth. This is useful when flushing and filling the system. The valve automatically returns to "AUTO" from "MAN" when it is electrically powered after manual use is terminated.

NOTE: Push the manual lever slowly to prevent overstressing the motor and gear system otherwise damage may occur.

### Auxiliary switches

All versions are also available with one or two auxiliary microswitches. These are activated by opening the valve using a cam. The microswitch contacts are independent from the valve's electrical circuit. Versions with a single-pole microswitch (version M1) and a two-pole microswitch

## Solar motorized valves

version M15) are available as well as versions with two microswitches (version M2 or M2S). A special kit can be supplied for installing an auxiliary single-pole microswitch on valve versions that are not equipped with it at the factory (kit M1). Kits M1S, M2 and M2S cannot be retrofitted on valve outside the factory.

### Ordinary maintenance instructions

The valve does not require maintenance when the plumbing system is not in use, nor does it require specific cleaning or maintenance. Check that the electrical supply cable is in good condition. If it is necessary to clean the valve, ensure the electrical supply is isolated and that fluid is not passing through the valve. Contact a service centre whenever problems are encountered.

### Technical Data

- Rated power supply 1ph / 230 V a.c. / 50 Hz
- Absorbed power: 5 ÷ 6 W
- Degree of protection IP20 IEC 529 European Standards Ref. CEI EN 60529
- Auxiliary contact capacity 3 A, 230 Vac
- Maximum differential pressure:  
2 port: 22mm, and 28mm = 90.2kPa  
3 port: 15mm and 22mm = 154 kPa, 28mm 61kPa
- Rated pressure PN10
- Flow temp. limits: +5 ÷ 160 °C
- Maximum room temperature: 60 °C
- Nominal opening time 10 sec (2 port), 20 sec (3 port).
- Nominal closing time 4 sec (2 port), 6 sec (3 port).
- Standard Cable Length 550 mm.

### Pressure Drop details

| 2 port Valve Size | Kvs                 |
|-------------------|---------------------|
| 22mm              | 7 m <sup>3</sup> /h |
| 28mm              | 9 m <sup>3</sup> /h |

| 3 port Valve Size | Kvs                    |
|-------------------|------------------------|
| 15mm              | 6.6 m <sup>3</sup> /h  |
| 22mm              | 7.8 m <sup>3</sup> /h  |
| 28mm              | 12.6 m <sup>3</sup> /h |

### Note:

**Kvs = volume flow rate through the valve with 1.0 bar pressure loss**

### Operation

#### Two-way zone valves

These valves are furnished with port A normally closed (without electrical supply), where the shut-off ball closes port A due to the force exercised by the return springs.

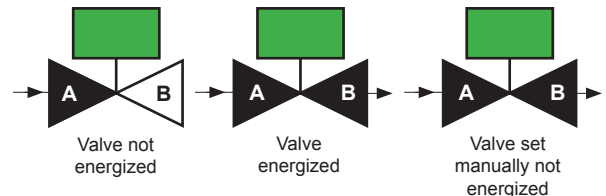

When the electrical supply is activated, the servo motor overcomes the force of the spring and moves the ball from port A to an intermediate (fully open) position in about 10 seconds. It maintains the ball in that position until the electrical supply is interrupted. When the electrical supply is interrupted the return springs drives the valve back and closes port A, this takes about 4 seconds.

#### Three-way diverting valves

These valves are furnished with port A normally closed (without electrical supply), where the ball closes port A due to the force exercised by the return springs.

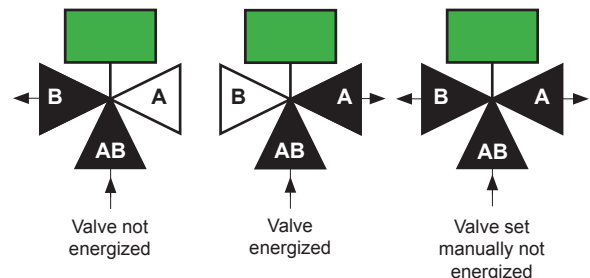

When the electrical supply is activated, the servo motor overcomes the force of the spring and drives the ball from port A to port B position, this takes about 20 seconds. Fluid then flows through port A. It maintains the ball in that position until the electrical supply is interrupted. When the electrical supply is interrupted the return springs drives the valve back on port A and allows the fluid to flow through port B, this takes about 6 seconds.

| Cat No.  | Description   |
|----------|---|
| SMV 2530 | 22mm 2-port solar zone valve (3 wire) without auxiliary switch  |
| SMV 2430 | 22mm 2-port solar zone valve (5 wire) with auxiliary switch     |
| SMV 2431 | 28mm 2-port solar zone valve (5 wire) without auxiliary switch  |
| SMV 3415 | 15mm 3-port solar diverter valve (5 wire) with auxiliary switch |
| SMV 3417 | 22mm 3-port solar diverter valve (5 wire) with auxiliary switch |
| SMV 3418 | 28mm 3-port solar diverter valve (5 wire) with auxiliary switch |

## Solar motorized valves

\* Note: To ensure water from either condensation or a leaking valve does not enter the actuator, do not install the valve upside down with the cover underneath the valve body.

Always allow adequate room around the valve to access the actuator for installation and maintenance purposes.

### Dimensions

#### 2-Port valve

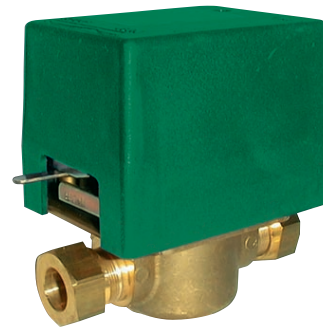
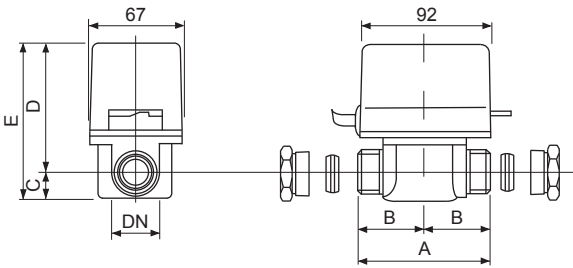

2-port spring return motorized valve

| Valve               | DN   | A  | B  | C  | D  | E   |
|---------------------|------|----|----|----|----|-----|
| SMV 2530 & SMV 2430 | 22mm | 92 | 46 | 20 | 85 | 105 |
| SMV 2431            | 28mm | 92 | 46 | 20 | 85 | 105 |

#### 3-Port valve

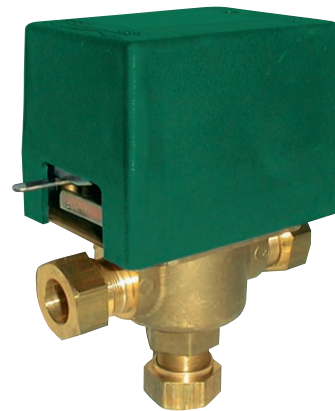
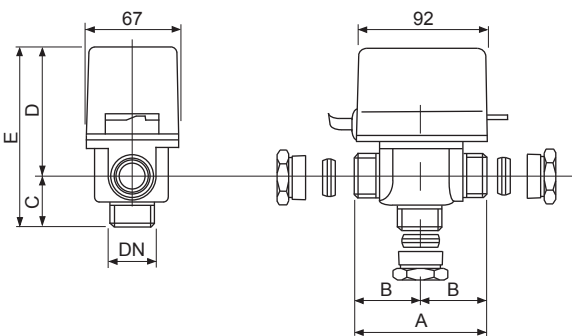

3-port spring return motorized valve

| Valve    | DN   | A   | B  | C  | D  | E   |
|----------|------|-----|----|----|----|-----|
| SMV 3415 | 15mm | 106 | 53 | 53 | 84 | 137 |
| SMV 3417 | 22mm | 106 | 53 | 53 | 84 | 139 |
| SMV 3418 | 28mm | 120 | 60 | 60 | 88 | 148 |